

TM 11-5542

DEPARTMENT OF THE ARMY TECHNICAL MANUAL

ELECTRIC

LIGHT

ASSEMBLY

MX-1291/PAQ

This copy is a reprint which includes current pages from Changes 2 and 3.

Change in force: C 2

TM 11-5542
*C 2

TECHNICAL MANUAL
ELECTRIC LIGHT ASSEMBLY
MX-1291/PAQ

TM 11-5542 }
CHANGES No. 2 }

HEADQUARTERS,
DEPARTMENT OF THE ARMY
WASHINGTON, D.C., 3 October 1963

TM 11-5542, 16 July 1953, is changed as indicated so that the manual also applies to the following equipment (as changed by C 1, 18 December 1959):

| <i>Nomenclature</i> | <i>Order No.</i> | <i>Serial No.</i> |
|---------------------------------------|------------------|-------------------|
| Light Assembly, Electric, MX-1291/PAQ | 9144-PP-59 | 1 to 250 |

Page 1, chapter 1 (as changed by C 1, 18 December 1959). Add the following note below the title of chapter 1.

Note. Light Assembly, Electric, MX-1291/PAQ procured on Order No. 9144-PP-59 is similar to equipment previously procured. Information in this manual applies to all equipments unless otherwise specified.

Add paragraph 1.1 after paragraph 1.

1.1. Index of Publications

Refer to the latest issue of DA Pam 310-4 to determine whether there are new editions, changes, or additional publications pertaining to the equipment. DA Pam 310-4 is an index of current technical manuals, technical bulletins, supply bulletins, lubrication orders, and modification work orders available through publications supply channels. The index lists the individual parts (-10, -20, -35P, etc.) and the latest changes to and revisions of each equipment publication.

Delete paragraph 2 and substitute:

2. Forms and Records

a. Reports of Maintenance and Unsatisfactory Equipment. Use equipment forms and records in accordance with instructions in TM 38-750.

b. Report of Damaged or Improper Shipment. Fill out and forward DD Form 6 (Report of Damaged or Improper Shipment) as prescribed in AR 700-58 (Army), NAVSANDA Publication No. 378 (Navy), and AFR 71-4 (Air Force).

c. Reporting of Equipment Manual Improvements. The direct reporting by the individual user of errors, omissions, and recommenda-

* This change supersedes C 1, 18 December 1959.

tions for improving this equipment manual is authorized and encouraged. DA Form 2028 (Recommended changes to DA technical manual parts lists or supply manual 7, 8, or 9) will be used for reporting these improvement recommendations. This form will be completed in triplicate using pencil, pen, or typewriter. The original and one copy will be forwarded direct to Commanding Officer, U.S. Army Electronics Materiel Support Agency, ATTN: SELMS-MP, Fort Monmouth, N.J. 07703. One information copy will be furnished to the individual's immediate supervisor (officer, noncommissioned officer, supervisor, etc.).

Page 6, paragraph 9b, line 2 (as changed by C 1, 18 December 1959). Change "(C, fig 4)" to: (D, fig 4); also change "(D, fig. 4)" to: (C, fig. 4).

Page 9, paragraph 10c (As changed by C 1, 18 December 1959). Make the following changes:

Line 2. Change "(C, fig. 4)" to: (D, fig. 4).

Line 7. Change "(D, fig. 4)" to: (C, fig. 4).

Page 13. Chapter 3, heading. Change "ORGANIZATIONAL MAINTENANCE" INSTRUCTIONS to: OPERATOR'S AND ORGANIZATIONAL MAINTENANCE.

Delete section I and substitute:

Section I. OPERATOR'S PREVENTIVE MAINTENANCE

16. Scope of Operator's Maintenance

The maintenance duties assigned to the operator of the equipment are listed below together with a reference to the paragraphs covering the specific maintenance function. Materials required for operator's maintenance are listed in paragraph 17.

- a. Daily preventive maintenance checks and services (par. 19.1).
- b. Weekly preventive maintenance checks and services (par. 19.2).
- c. Cleaning (par. 19.3).

17. Materials Required for Operator's Maintenance

- a. Lint-free cloth.
- b. Cleaning compound (FSN 7930-395-9542).

18. Operator's Preventive Maintenance

Operator's preventive maintenance is the systematic care, servicing, and inspection of equipment to prevent the occurrence of trouble, to reduce downtime, and to assure that the equipment is serviceable.

a. *Systematic Care.* The procedures given in paragraphs 19 through 19.3 cover routine systematic care and cleaning essential to proper upkeep and operation of the equipment.

b. *Preventive Maintenance Checks and Services.* The preventive maintenance checks and services charts (pars. 19.1 and 19.2) outline

functions to be performed at specific intervals. These checks and services are to maintain the equipment in a combat serviceable condition; that is, in good general (physical) condition and in good operating condition. To assist operators in maintaining combat serviceability, the chart indicates what to check, how to check, and the normal conditions. The *References* column lists the paragraphs that contain detailed repair or replacement procedures. If the defect cannot be remedied by the operator, higher echelon maintenance is required. Records and reports of these checks and services must be made in accordance with the requirements set forth in TM 38-750.

19. Preventive Maintenance Checks and Services Periods

Preventive maintenance checks and services of the equipment are required daily and weekly. Paragraphs 19.1 and 19.2 specify the items to be checked and serviced. In addition to the daily checks and services, the equipment should be rechecked and serviced immediately *before going on a mission and as soon after completion of the mission as possible.*

19.1. Daily Preventive Maintenance Checks and Services Chart

| Sequence No. | Item | Procedure | References |
|--------------|------------------------|---|------------|
| 1 | Switches..... | Check for positive action, freedom of movement, and secure mounting; tighten loose switch mountings as necessary. | Par. 19.3. |
| 2 | Short-wave filter..... | Check filter for cracks and cleanliness; clean as necessary. | |
| 3 | Case..... | Check case for dents, cleanliness, and ease of operation of removable door and spring latch; clean as necessary. | |

19.2. Weekly Preventive Maintenance Checks and Services Chart

| Sequence No. | Item | Procedure | References |
|--------------|------------------|---|------------|
| 1 | Lamps..... | Check to see that lamps are seated securely and none are cracked; clean lamps as necessary. | Par. 19.3. |
| 2 | Lampholders..... | Inspect for loose mounting screws; tighten screws as necessary. | |

19.2. Weekly Preventive Maintenance Checks and Services Chart—Continued

| Sequence No. | Item | Procedure | References |
|--------------|------------------------|---|------------|
| 3 | Cables and connectors. | Inspect for dirt, mildew, corrosion, and bent or spread contacts; straighten contacts and clean as necessary. | |

19.3. Cleaning

a. Shortwave Filter. Moisten, but do not soak, a clean lint-free cloth in cleaning compound. Wipe the surfaces and allow to dry naturally.

b. Lamps. Remove lamps and clean them. Use the same method described in *a* above.

Caution: Be sure lamps are cold before removing and cleaning. Lamps may break if cleaned while hot.

c. Case. Clean the exterior and interior of the case. Use the same method described in *a* above.

Page 16. Delete section II and substitute:

Section II. ORGANIZATIONAL PREVENTIVE MAINTENANCE

20. Scope of Organizational Maintenance

The maintenance duties assigned to organizational maintenance personnel of the equipment are listed below together with a reference to the paragraphs covering the specific maintenance function.

- a.* Monthly preventive maintenance checks and services (par. 21.3).
- b.* Touchup painting (par. 21.4).

21. Materials and Test Equipment Required for Organizational Maintenance

In addition to the materials listed in paragraph 17, the following items are required:

- a.* Multimeter TS-297/U.
- b.* Sandpaper (No. 000).

21.1. Organizational Preventive Maintenance

a. Organizational preventive maintenance is the systematic care, inspection, and servicing of equipment to maintain it in serviceable condition, prevent breakdowns, and assure maximum operational capability. Preventive maintenance is the responsibility of all echelons concerned with the equipment and includes inspection, testing,

and repair or replacement of parts, subassemblies, or units that inspection and tests indicate would probably fail before the next scheduled periodic service. Preventive maintenance checks and services of the equipment at the second echelon level are made at monthly intervals at the same time as the daily (par. 19.1) and weekly (par. 19.2) checks and services unless otherwise directed by the commanding officer.

b. Maintenance forms and records to be used and maintained on this equipment are specified in TM 38-750.

21.2. Monthly Maintenance

Perform the maintenance functions indicated in the monthly preventive maintenance checks and services chart (par. 21.3) once each month. A month is defined as approximately 30 calendar days of 8-hour-per-day operation. If the equipment is operated 16 hours a day, the monthly preventive maintenance checks and services should be performed at 15-day intervals. Adjustment of the maintenance interval must be made to compensate for any unusual operating conditions. Equipment maintained in a standby (ready for immediate operation) condition must have monthly preventive maintenance checks and services. Equipment in limited storage (requires service before operation) does not require monthly preventive maintenance.

21.3. Monthly Preventive Maintenance Checks and Services Chart

| Sequence No. | Item | Procedure | References |
|--------------|---------------------|--|---------------|
| 1 | Completeness..... | See that the equipment is complete. | Par. 5. |
| 2 | Publications..... | See that all publications are complete, serviceable, and current. | DA Pam 310-4. |
| 3 | Modifications..... | Check DA Pam 310-4 to determine if new applicable MWO's have been published. All URGENT MWO's must be applied immediately. All NORMAL MWO's must be scheduled. | |
| 4 | Operation..... | Operate the equipment on ac power and then on battery. | Par. 24. |
| 5 | Battery RA-1419/U.. | Check the 90-volt output of the battery. Use Multi-meter TS-297/U while the equipment is operating on battery. | Par. 24. |

21.3. Monthly Preventive Maintenance Checks and Services Chart—Continued

| Sequence No. | Item | Procedure | References |
|--------------|-------------|---|---|
| 6 | Case..... | <p>a. Check all exterior surfaces for evidence of fungus, rust, and corrosion.</p> <p>b. Check all interior surfaces for evidence of fungus, rust, and corrosion. Pay close attention to the battery compartment for corrosive material which may have escaped from the battery case.</p> | <p>a. Par. 21.4.</p> <p>b. Par. 21.4.</p> |
| 7 | Cables..... | Check cables for abrasions, cuts, and breaks in insulation; repair as necessary. | |

21.4. Touchup Painting

Remove rust and corrosion from metal surfaces by lightly sanding them with fine sandpaper. Brush two thin coats of paint on the bare metal to protect it from further corrosion. Refer to the applicable cleaning and refinishing practices specified in TM 9-213.

Page 17, paragraph 23. Make the following changes:

Subparagraph *a*, line 2. Delete "the operator".

Subparagraph *c*. Delete and substitute:

c. Normal Indication. The normal indications listed are visible signs that should be perceived when the item is checked. If the indications are not normal, apply the recommended corrective measures.

Subparagraph *d*. Delete the first sentence and substitute: The corrective measures listed are those that can be applied without turning the equipment in for repairs.

Page 24, figure 10 (as changed by C 1, 18 December 1959). Add the following note:

Note. A dust cover (not shown) is added to the chassis at the rear of switches S1(4), S2(7), and S3(9) on equipments bearing order No. 9144-PP-59.

Page 28, appendix I. Delete appendix I and substitute:

APPENDIX I REFERENCES

Following is a list of applicable publications available to the operator and organizational maintenance personnel.

| | |
|--------------|--|
| DA Pam 310-4 | Index of Technical Manuals, Technical Bulletins, Lubrication Orders, and Modification Work Orders. |
| TM 9-213 | Painting Instructions for Field Use. |
| TM 11-5500 | Multimeter TS-297/U. |
| TM 38-750 | The Army Equipment Records and Procedures. |

By Order of the Secretary of the Army:

EARLE G. WHEELER,
General, United States Army,
Chief of Staff.

Official:

J. C. LAMBERT,
Major General, United States Army,
The Adjutant General.

Distribution:

Active Army:

| | |
|-----------------------|------------------------------------|
| DASA (6) | Sig Dep (OS) (12) |
| USASA (2) | Sig Sec, GENDEP (5) |
| CNGB (1) | Army Dep (2) except Utah (5) |
| CofEngrs (1) | Ft Worth (8) |
| TSG (1) | Lexington (12) |
| CSigO (7) | Sacramento (28) |
| CofT (1) | Tobyhanna (12) |
| C of SptS (1) | USA Trans Tml Comd (1) |
| USA CD Agcy (1) | Army Tml (1) |
| USCONARC (5) | USAOSA (1) |
| USAMC (5) | POE (1) |
| ARADCOM (2) | WRAMC (1) |
| ARADCOM Rgn (2) | AMS (1) |
| OS Maj Comd (3) | AFIP (1) |
| OS Base Comd (2) | Army Pic Cen (2) |
| LOGCOMD (2) | USA Mbl Spt Cen (1) |
| USAECOM (5) | USA Elct Mat Agcy (12) |
| USAMICOM (4) | Chicago Proc Dist (1) |
| USASCC (4) | USA Elct RD Actv, White Sands (13) |
| MDW (1) | USA Elct RD Actv, Ft Huachuca (2) |
| Armies (2) | USARSOUTHCOM Sig Agcy (1) |
| Corps (2) | Sig Fld Maint Shop (3) |
| USA Corps (3) | Harry Diamond Lab (2) |
| USATC AD (2) | USA Criminal Invest Lab (2) |
| USATC Engr (2) | Units org under fol TOE (2 cy ea): |
| USATC Inf (2) | 7 19-27 29-51 |
| USATC Armor (2) | 7-100 19-29 29-75 |
| USASTC (5) | 12-37 19-500 29-105 |
| Instl (2) except | 12-157 (Tms 37 |
| Ft Monmouth (65) | 12-167 AA- 37-100 |
| Svc Colleges (2) | 12-177 AE) 57 |
| Br Svc Sch (2) except | 17 29-1 57-100 |
| GENDEP (OS) (2) | 17-100 29-21 |

NG: State AG (3).

USAR: None

For explanation of abbreviations used, see AR 320-50.

TM 11-552 }
CHANGE No. 3 }

HEADQUARTERS,
DEPARTMENT OF THE ARMY
WASHINGTON, D.C., 4 August 1965

ELECTRIC LIGHT ASSEMBLY MX-1291/PAQ

TM 11-5542, 16 July 1953, is changed as follows:

Note. The parenthetical reference to previous changes (example: page 1 of C 2) indicates that pertinent materila was published in that change.

Page 1, paragraph 1.1 (page 1 of C 2), line 4. After technical bulletin, insert: supply manuals (types 4, 6, 7, 8, and 9), supply catalogs (type CL).

Delete paragraph 2c (page 1 of C 2) and substitute:

c. Reporting of Equipment Manual improvements. The direct reporting of errors, omissions, and recommendations for improving this manual by the individual user, is authorized and enoucraged. DA Form 2028 (Recommended Changes to DA Publications) will be used for reporting these improvements. This form willbe completed using pencil, pen, or typewriter and forwarded direct to Commanding General, U.S. Army Electronics Command, ATTN: AMSEL-MR-(NMP)-MA, Fort Manmouth, N.J., 07703.

Page 16, paragraph 21.4 (page 6 of C 2), last line. Change TM 9-213 to TB SIG 364.

Page 22, Section II. Change heading to: REPAIRS.

Page 25. Make the following changes:

Delete paragraph 30.

Add section III after section II:

Section III. DEPOT INSPECTION STANDARDS

30. Applicability of Depot Inspection Standards

The tests outlined in this section are designed to measure the performance capability of a repaired equipment. Equipment that is to be returned to stock should meet the standards given in these tests.

30.1 Applicable References

a. Repair Standards. Applicable paragraphs of TB SIG 355-1 form a part of this standard.

*This changs replaced Repaired Equipment Standard No. REP-802, Issue No. 1, 4 August 1953.

b. Modification Work Orders. Perform all modification work orders applicable to this equipment before making the tests specified. DA Pam 310-4 lists all available MWO's.

30.2 Test Facilities Required

Fluorescent paint, white, FSN 8010-082-2599, is required. Fabricate a test target by applying a coat of this paint to a piece of wood or cardboard measuring approximately 12 inches by 12 inches.

30.3 General Test Requirements

- a.* Connect the equipment to 115-volt, 60-cps power.
- b.* Install a fresh batterh in the equipment.

30.4 Ac Operational Test

- a.* Set the power switch to the AC ON position.
- b.* Energize the germicidal lamp by operating the MOMENTARY ON-OFF switch (D, fig. 4).
- c.* The fluorescent test target should fluoresce at a minimum range of 12 feet in total darkness.
- d.* Momentarily set the power switch to the OFF position and then return it to the AC ON position.
- e.* Energize the black-light lamp by operating the MOMENTARY ON-OFF switch (C, fig. 4).
- f.* The fluorescent test target should fluoresce at a minimum range of 6 feet in total darkness.
- g.* Set the power switch to the OFF position.

30.5 Dc Operational Test

- a.* Set the power switch to the DC ON position
- b.* Repeat the procedures given in paragraph 30.4 *b* through *g*, except in *d*, momentarily set the power switch to the OFF position, and then return the power switch to the DC ON position.

Page 28, appendix I (page 1 of C 2). Make the following changes:

Delete DA Pam 310-4 and its title and substitute:

DA Pam 310-4 Index of Technical Manuals, Technical Bulletins, Supply Manuals (types 4, 6, 7, 8, and 9), Supply Catalogs (type CL), Supply Bulletins, Lubrication Orders, and Modification Work Orders.

Delete TM 9-213

Add the following references:

TB SIG 355-1 Depot Inspection Standard for Repaired Signal Equipment.

TB SIG 364 Field Instructions for Painting and Preserving Electronics Command Equipment.

By Order of the Secretary of the Army:

HAROLD K. JOHNSON,
General, United States Army,
Chief of Staff.

Official:

J.C. LAMBERT,
Major General, United States Army,
The Adjutant General.

Distribution:

Active Army

| | |
|-----------------------|---------------------------------------|
| USASA (2) | WRAMC (1) |
| CNGB (1) | Army Pic Cen (2) |
| CC E (7) | Instl (2) except |
| Dir of Trans (1) | Ft Monmouth (70) |
| Cof Engrs (1) | Ft Hancock (4) |
| TSG (1) | Ft Gordon (10) |
| CofSptS (1) | Ft Huachuca (10) |
| USACDCEA (1) | Ft Carson (25) |
| USACDCCBRA (1) | WSMR (5) |
| USACDCCEA (1) | GENDEP (2) |
| USACDCOA (1) | Sig Sec GENDEP (5) |
| USACDCQMA (1) | Sig Dep (12) |
| USACDCTA (1) | A Dep (2) Except |
| USACDCADA (1) | SAAD (30) |
| USACDCARMA (1) | TOAD (14) |
| USACDCAVNA (1) | FTWOAD (10) |
| USACDCARYTA (1) | LEAD (7) |
| USACDCSWA (1) | SHAD (3) |
| USACDCCEA | NAAD (5) |
| Ft Huachuca (1) | SVAD (5) |
| USAMC (5) | CHAD (3) |
| USCONACR (5) | ATAD (3) |
| ARADCOM (5) | LBAD (14) |
| ARADCOM Rgu (2) | UTAD (5) |
| OS Maj Cored (4) | Sig Fld Maint Shops (2) |
| LOGCOMD (2) | AMS (1) |
| USAMICOM (4) | USAERDAA (2) |
| USASMA (2) | USAERDAW (13) |
| USASCC (4) | NLAB (5) |
| MDW (1) | Units organized under following TOE's |
| Armies (2) except | (2 copies each unless otherwise indi- |
| EUSA (5) | cated): |
| USAREUR (5) | 7 11-587 29-1 |
| Corps (2) | 7-100 11-592 29-11 |
| USAC (3) | 11-16 11-597 29-21 |
| 11th Air Aslt Div (3) | 11-57 12-37 29-51 |
| LGII (5) | 11-97 12-157 29-56 |
| Sve Colleges (2) | 11-98 12-167 29-75 |
| Br Sve Sch (2) | 11-117 12-177 29-105 |
| USASTC (2) | 11-155 17 30-25 |
| USATC AD (2) | 11-157 19-27 37 |
| USATC Armor (2) | 11-337 19-29 37-100 |
| USATC Engr (2) | 11-500 (AA- 19-500 (AA- 57 |
| USATC Inf (2) | AE) (4) AE) 57-100 |

NG: State AG (3).

USAR: None.

For explanation of abbreviations used, see AR 320-50.

DEPARTMENT OF THE ARMY TECHNICAL MANUAL

TM 11-5542

**ELECTRIC
LIGHT
ASSEMBLY
MX-1291/PAQ**

DEPARTMENT OF THE ARMY

JULY 1953

*United States Government Printing Office
Washington: 1953*

AGO 4602B

DEPARTMENT OF THE ARMY
WASHINGTON 25, D. C., 16 July 1953

TM 11-5542 is published for the information and guidance of all concerned.

[AG 412.42 (3 Jun 53)]

BY ORDER OF THE SECRETARY OF THE ARMY:

OFFICIAL:

WM. E. BERGIN
Major General, USA
The Adjutant General

J. LAWTON COLLINS

Chief of Staff, United States Army

DISTRIBUTION:

Active Army:

Tech Svc (1) ; Tech Svc Bd (1) ; AFF Bd (ea Svc Test Sec) (1) ; AFF (5) ; AA Cored (2) ; OS Maj Cored (5) ; Base Cored (5) ; MDW (2) ; Log Cored (5) ; A (5) ; CHQ (2) ; FT (2) ; Sch (5) except 11 (25) ; PMS&T 11 (1) ; Gen Dep (2) ; Dep 11 (20) ; except Sig Sec, Gen Dep (10) ; Tng Div (2) ; POE (10), OSD (2) ; Lab 11 (5) ; Mil Dist (3) ; Field Maint Shops 11 (3) ; Two (2) copies to each of the following T/O&E's: 11-107; 11-127A; 11-128 ; 11-500A, CA, CB, CC, CD; 11-587 ; 11-592 ; 11-597.

NG: Same as Active Army except one copy to each unit.

Army Reserve: Same as Active Army except one copy to each unit.

For explanation of distribution formula, see SR 310-90-1.

WARNING
THE OPERATOR MUST WEAR GOGGLES
WHEN THE GERMICIDAL LAMP IS LIT

Exposure of the eyes to short-wave radiation will cause sunburn of the eyeball or even erythema. This equipment emits both short-wave and long-wave ultraviolet radiation. The warning applies only to short-wave radiation, which is emitted by the 4-watt germicidal lamp in the center of the unit. When this lamp is used for protracted periods, the eyes should be protected by suitable glass goggles, ordinary clear glass, or spectacles. Although a few moments exposure will not be harmful, do not use the germicidal lamp for more than 15 seconds without protection.

CONTENTS

| | <i>Paragraph</i> | <i>Page</i> |
|---|------------------|-------------|
| CHAPTER 1. INTRODUCTION | | |
| <i>Section I.</i> General----- | 1,2 | 1 |
| <i>II.</i> Description and data----- | 3-7 | 1 |
| CHAPTER 2. OPERATING INSTRUCTIONS | | |
| <i>Section I.</i> Operation under usual conditions ----- | 8-11 | 6 |
| <i>II.</i> Operation under unusual conditions ----- | 12-15 | 11 |
| CHAPTER 3. ORGANIZATIONAL MAINTENANCE INSTRUCTIONS | | |
| <i>Section I.</i> Preventive maintenance services ----- | 16-19 | 13 |
| <i>II.</i> Weatherproofing ----- | 20,21 | 16 |
| <i>III.</i> Trouble shooting at organizational maintenance level. | 22-24 | 16 |
| CHAPTER 4. FIELD MAINTENANCE INSTRUCTIONS | | |
| <i>Section I.</i> Trouble shooting at field maintenance level ----- | 25-27 | 20 |
| <i>II.</i> Repairs and final testing ----- | 28-30 | 22 |
| CHAPTER 5. SHIPMENT AND LIMITED STORAGE AND DEMOLITION TO PREVENT ENEMY USE | | |
| <i>Section I.</i> Shipment and limited storage ----- | 31,32 | 26 |
| <i>II.</i> Demolition to prevent enemy use ----- | 33,34 | 26 |
| APPENDIX I. REFERENCES ----- | ---- | 28 |
| II. IDENTIFICATION TABLE OF PARTS ----- | ---- | 30 |
| INDEX----- | ---- | 32 |

CHAPTER 1

INTRODUCTION

Section I. GENERAL

1. Scope

a. This technical manual contains instructions on the operation, organizational maintenance, and field maintenance of the equipment, as well as a discussion of the theory of operation. The instructions apply only to Electric Light Assembly MX-1291/PAQ.

b. Appendix I contains a list of current references, including supply manuals, technical manuals, and other available publications applicable to the equipment. Appendix II contains an identification table of parts.

2. Forms and Records

The following forms will be used for reporting unsatisfactory conditions of Army equipment.

a. DD Form 6, Report of Damaged or Improper Shipment, will be filled out and forwarded as prescribed in SR 745-45-5 (Army), Navy Shipping Guide Article 1850-4, and AFR 71-4 (Air Force).

b. DA Form 468, Unsatisfactory Equipment Report, will be filled out and forwarded to the Office of the Chief Signal Officer, as prescribed in SR 700-45-5.

c. AF Form 54, Unsatisfactory Report, will be filled out and forwarded to Commanding General, Air Materiel Command, Wright-Patterson Air Force Base, Dayton, Ohio, as prescribed in SR 700-45-5 and AFR 65-26.

d. Use other forms and records as authorized.

Section II. DESCRIPTION AND DATA

3. General (fig. 1)

Electric Light Assembly MX-1291/PAQ is a self-contained field unit used to excite fluorescence in certain materials by exposing

them to ultraviolet light. The equipment contains two ultraviolet-light sources, a 4-watt germicidal lamp for short-wave radiation and a 6-watt black-light lamp for long-wave radiation. A filter is used with the germicidal lamp to screen off light rays that are not required. The black-light lamp is self-filtered. The fluorescing of materials by ultraviolet light is used for investigation, identification, interception, and detection as follows:

a. Criminological Applications.

- (1) Raising and developing latent fingerprints.
- (2) Detecting semen in rape cases.
- (3) Detecting forgeries, falsified documents, and erasures.
- (4) Identifying currency, narcotics, dead bodies, clothing, blood stains, diamonds, and minerals.
- (5) Identifying fragmentary evidence at the scene of a crime.

b. Military Applications.

- (1) Revealing invisible writing.
- (2) Reading secret, invisible messages in code.
- (3) Facilitating ground operations during blackouts in the absence of visible light.
- (4) Identifying bearers of top security identification cards that have invisible coded signatures.
- (5) Facilitating night movements of scout and patrol parties when they advance to reconnoiter, and providing a means of back-tracking their trail when radio communication cannot be used.
- (6) Signaling at night during trench warfare when an invisible beam is necessary.
- (7) Locating missing night patrols in war zones by trailing their path of advance.
- (8) Maintaining convoy formation during night operations.
- (9) Reading military maps at night in combat zones.
- (10) Detecting fungi, and destroying bacteria, vermin, and other undesirable elementary forms of life.

4. Technical Characteristics

Power source 110- to 120-volt, 60-cycle ac, or Battery BA-419/U.

| | |
|-------|---|
| Lamps | Germicidal lamp (with filter) :2,280 to 4,400 angstrom units (peak at 2,537 angstrom units). Minimum range of 12 feet in total darkness. |
| | Black-light lamp (self-filtered) :3,100 to 4,620 angstrom units (peak at 3,650 angstrom units). Minimum range of 6 feet in total darkness. |

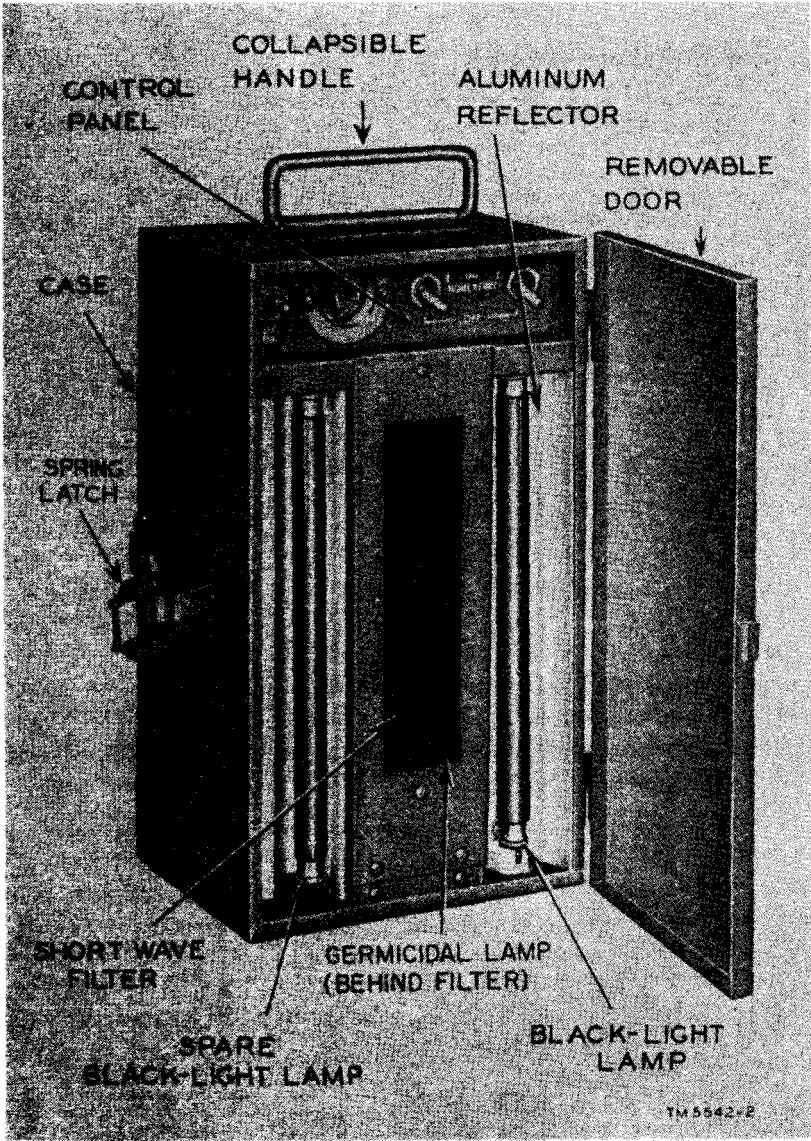

Figure 1. Electric Light Assembly MX-1291/PAQ, front view.

5. Table of Components

| Quantity | Component | Dimensions (in.) | | | Weight (lb) |
|----------|--|------------------|-------|-------|-------------|
| | | Length | Depth | Width | |
| 1 | Electric light assembly. | 11 1/8 | 5 1/4 | 6 1/4 | 7 1/4 |
| 1 | Power cable. | 72 | | | |
| 1 | Screw driver. | | | | |
| 1 | Set of spare parts: 1 Germicidal lamp. 1 Black-light lamp. 1 Short-wave filter. | | | | |

Note. This list is for general information only. See appropriate publications for information pertaining to the requisition of spare parts.

6. Description of Components

The control panel, lamps, and chassis of the electric light assembly are inclosed in a metal carrying case made of rust-proofed, painted metal. The case is equipped with a collapsible carrying handle and two doors. The front door, which covers the lamp section and the control panel, can be slipped off its hinges when the equipment is to be used. The back door, which is permanently attached, covers the battery, power cable, and spare parts compartments.

a. The control panel is located at the top front of the unit. At the left-hand side of the panel is a toggle switch marked AC ON-DC ON-OFF. Next to this switch is a receptacle connector, which is used to receive the a-c power cable. At the right-hand side of the panel are two toggle switches marked ON MOMENTARY-OFF. The switch to the far right is used to light the black-light lamp, and the other is used to light the germicidal lamp.

b. The germicidal lamp, covered by a short-wave filter, is located below the control panel in the center of the front section. The black-light lamp is located to the right of the germicidal lamp. Both lamps are backed by an aluminum reflector. To the left of the germicidal lamp is a spare black-light lamp.

c. The rear section of the equipment contains a battery compartment, a spare germicidal lamp, a spare short-wave filter, a 6-foot power cable; and a screw driver. Battery BA-419/U, which is required for d-c operation of the equipment, is not furnished with Electric Light Assembly MX-1291/PAQ.

7. Packaging Data

Packed for domestic shipment, Electric Light Assembly MX-1291 PAQ is included in a corrugated cardboard box $12\frac{3}{8}$ inches long by $6\frac{7}{8}$ inches wide by $5\frac{1}{4}$ inches high. The packaged equipment weighs $9\frac{1}{2}$ pounds. For export, nine packaged equipments are included in a wooden crate, which is $24\frac{3}{4}$ inches long by $12\frac{3}{4}$ inches wide by $21\frac{1}{2}$ inches high. The crated equipments weigh approximately 120 pounds.

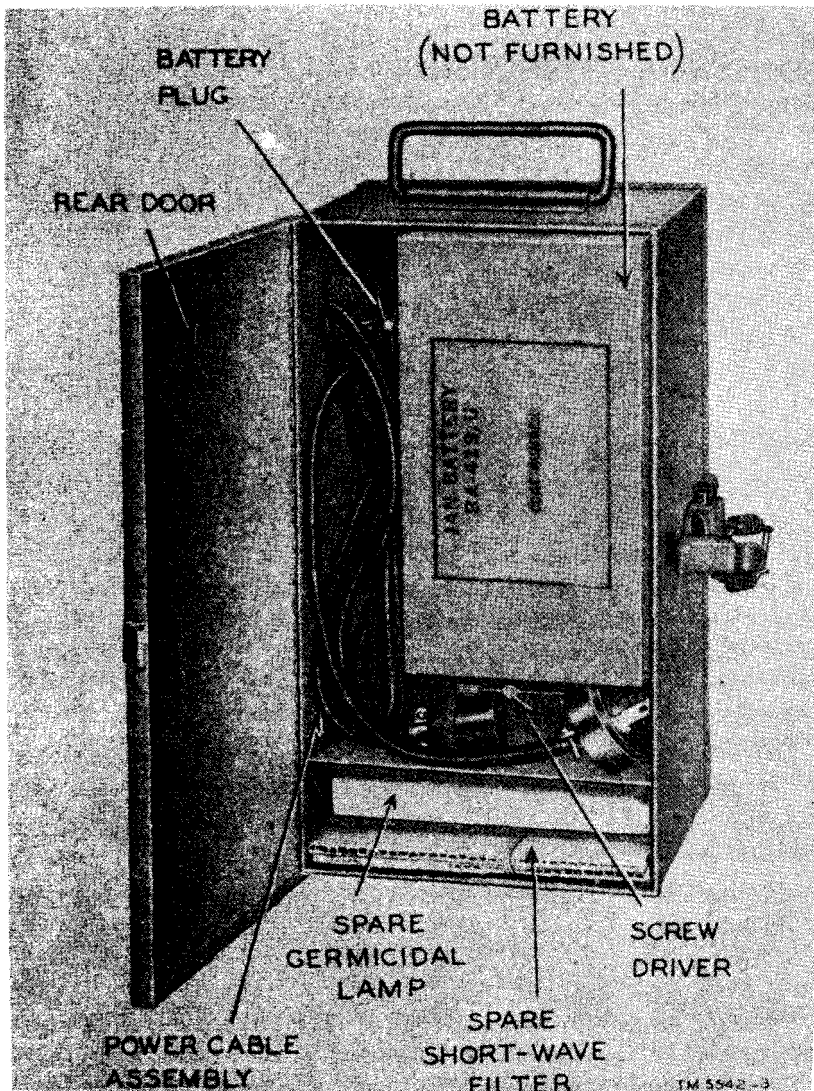

Figure 2. Electric Light Assembly MX-1291/PAQ.

CHAPTER 2

OPERATING INSTRUCTIONS

Section 1. OPERATION UNDER USUAL CONDITIONS

8. Uncrating and Unpacking

(fig. 3)

a. Uncrate Electric Light Assembly MX-1291/PAQ as follows:

- (1) Break the metal straps, and remove the nails with a nail puller.
- (2) Remove one of the cartons from the shipping crate, and set it in an upright position.
- (3) Slit the adhesive tape, and open the carton.
- (4) Slit the moisture-vaporproof bag at the closure, and lift out the inner carton without removing the bag from the outer carton.
- (5) Remove the gummed tape from the inner carton, and lift the equipment out by the carrying handle. Save the carton and packaging material for use in repacking.

b. Check the unpacked equipment against the table of components (par. 5), and inspect each item for possible damage incurred during shipment. Be sure that the filters and lamps are not cracked or broken.

9. Controls

(fig. 4)

a. *AC ON-DC ON-OFF Power switch* (A, fig. 4). This switch is used to turn power on or off for a-c or d-c operation. When the switch is in center position, power is off. When the switch is thrown up to the AC ON position, 110 volts ac (alternating current) are applied to the lamp circuit. When the switch is flipped down to the DC ON position, d-c voltage is applied to the lamp circuit by Battery BA-419/U.

b. *ON MOMENTARY-OFF Switches*. The germicidal-lamp switch (C, fig. 4) or the black-light-lamp switch (D, fig. 4) is thrown upward to turn on the associated lamp. The lamp will not light unless the AC ON-DC ON-OFF switch is in either AC ON or DC ON position, as required.

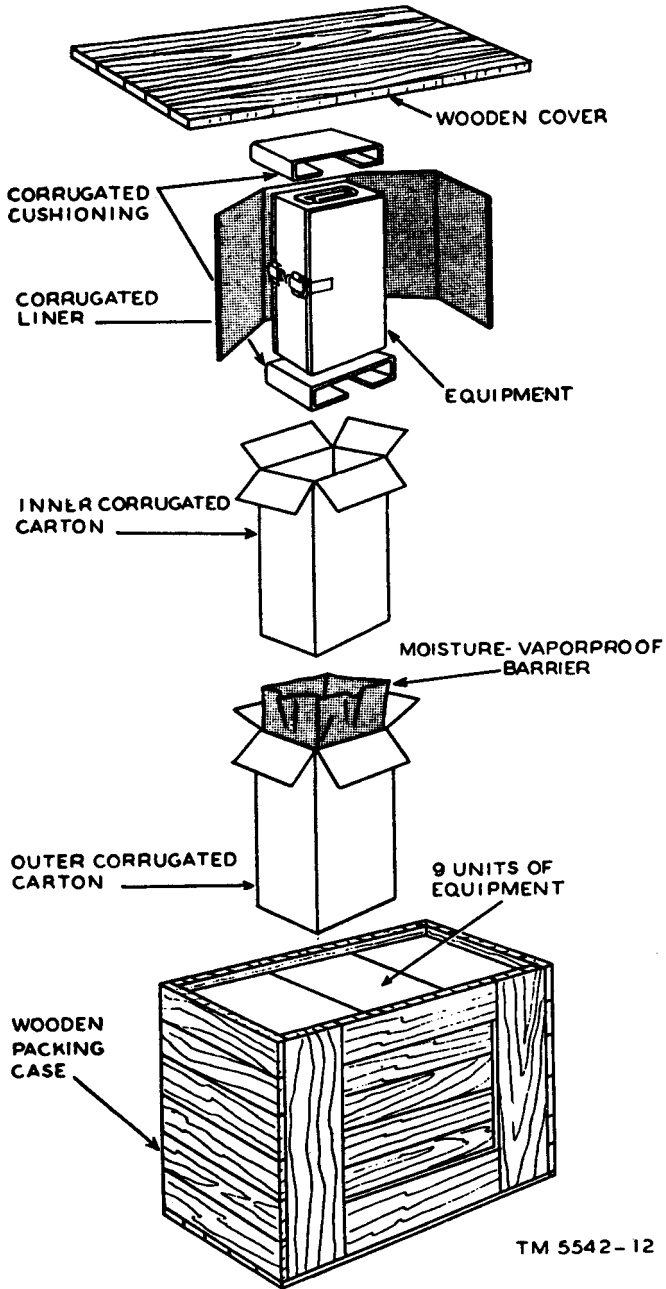

TM 5542-12

Figure 3. Packaging diagram.

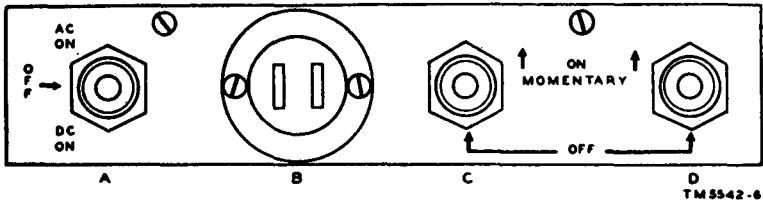

Figure 4. Control panel.

10. Starting Procedure

a. Set the equipment on a table or on the ground, open the front door, and remove the door from the slip hinges.

b. If a 110- to 120-volt a-c outlet is available, open the back door and remove the power cable. Insert the female plug on the

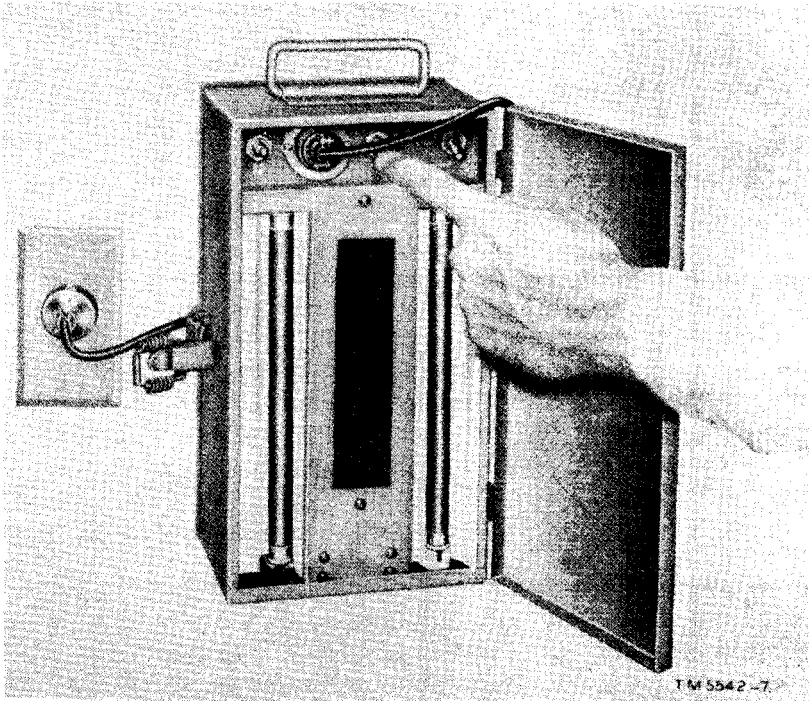

Figure 5. Power cable attached for a-c operation.

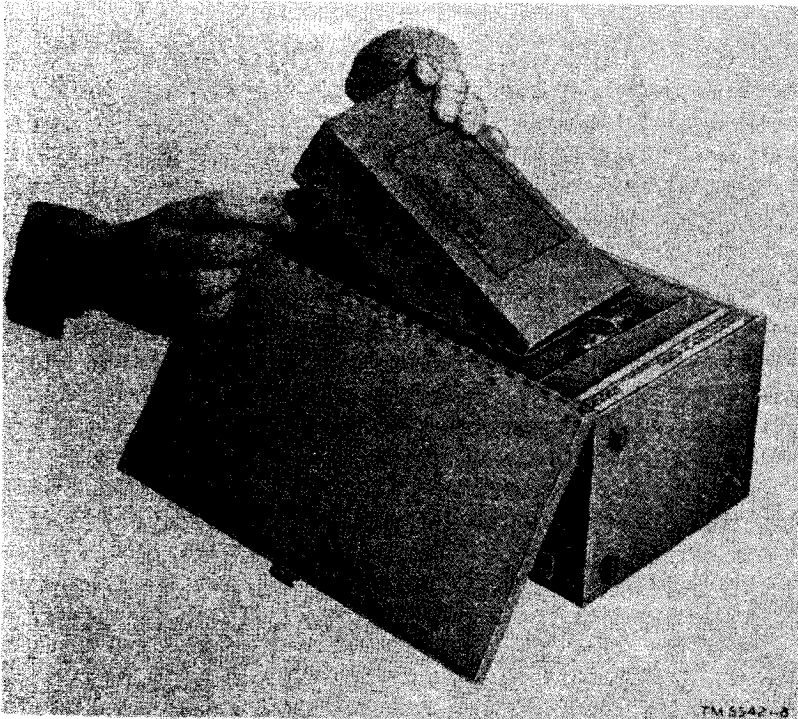

Figure 6. Connecting battery for d-c operation.

cable in the receptacle connector on the control panel, and insert the male plug in the power outlet (fig. 5). Then throw the power switch to the AC ON position. If a-c power is not available, lay the equipment face down and open the back door. Lift the battery up, and connect the battery plug to the receptacle provided (fig. 6). Close the door, and set the equipment upright. Throw the power switch to the DC ON position.

c. To turn on the germicidal lamp, push the associated switch (C, fig. 4) upward, hold it up for a few seconds, and then let it return to normal position. When the lamp is on, a flash of red-violet light will be seen at the bottom of the short-wave filter in front of the lamp. The flash soon diffuses, and the entire filter glows with a deep blue-violet hue. To turn on the black-light lamp, push the associated switch (D, fig. 4) upward, hold it up for a few seconds, and then let it return to normal position. The lamp should flicker briefly and then glow with a steady deep-violet hue.

11. Using Equipment (fig. 7)

a. Turn on the black-light lamp, and place the object to be examined in the direct beam of the lamp. If the object is responsive to long-wave ultraviolet radiation, it will fluoresce. If it does not fluoresce, throw the power switch to the OFF position to turn off the black-light lamp. Then throw the switch back at the AC ON or DC ON position, whichever is being used, and turn on the germicidal lamp. Place the object to be examined in the direct beam of the lamp. The object will fluoresce if it is responsive to short-wave ultraviolet radiation. If neither the black-light lamp nor the germicidal lamp produces fluorescence, it may be assumed that the object does not possess fluorescent properties.

b. The following table specifies characteristic fluorescent properties of some items frequently encountered in crime detection and identification work:

| Substance | Natural color | Fluorescence excited by germicidal lamp and filter | Fluorescence excited by black-light lamp | Form of substance |
|------------------|------------------|--|--|-----------------------|
| Laundry markings | Invisible | Light blue | Intense light blue | In solution |
| Blood | Red | None | Yellowish-red | In acid solution |
| Urine | Variable | Yellow | Weak yellow | Natural state |
| Teeth | Bone white | Blue-white | Intense blue-white | Natural state |
| Cocaine | White | Light blue | Blue-white | Powdered |
| Heroin | White | Light blue | Yellow-gray | Powdered |
| Morphine | White | Pale green | Pale green | In solution |
| Codeine | White | None | Weak gray | Powdered |
| Motor oils | Variable | Blue | Strong light blue | Refined |
| Silver | Gray | Violet | Violet | Lump |
| Arsenic | Black | None | Blue | Lump |
| Iodine | Purple-black | None | Blue | Lump or crystal |
| Platinum | Silvery | None | Violet | Solid state |
| Uranium | Variable | Yellow-green | Bright yellow-green | Solid state |
| Fungi | Variable | None | Violet | Natural state |
| Fungus varnish | Water color | Blue-gray | Strong blue-gray | Varnish |
| Semen | Transparent gray | Light blue | Blue-white | Natural, after drying |

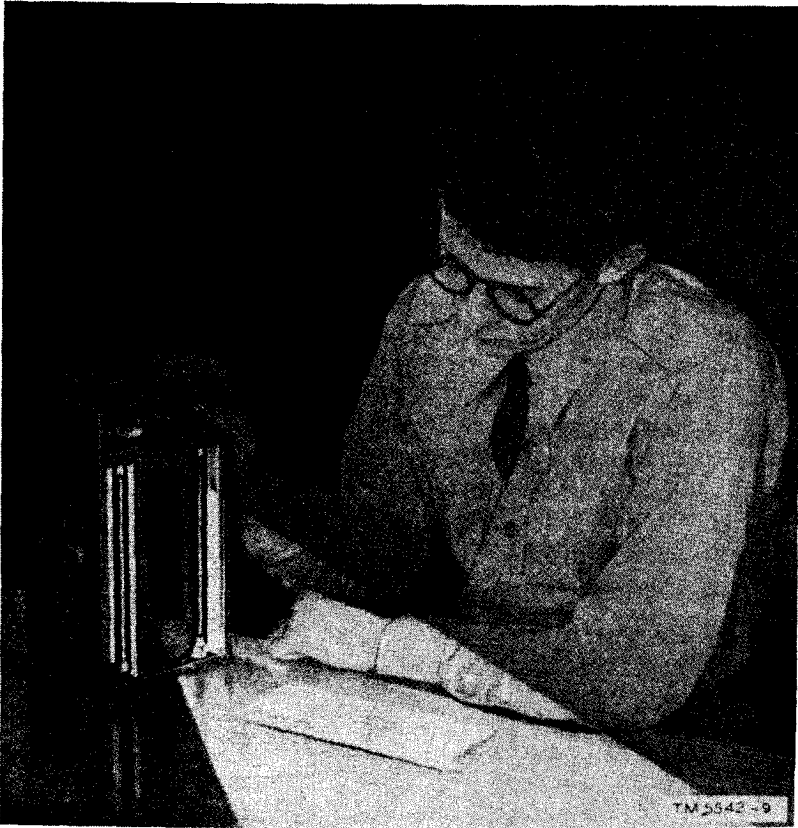

Figure 7. Using germicidal lamp.

Section II. OPERATION UNDER UNUSUAL CONDITIONS

12. Operation in Daylight

Electric Light Assembly MX-1291/PAQ should be used in total darkness. When it must be used in daylight, hold a coat or helmet over the top of the case to prevent dissipation of the ultraviolet radiation by the daylight.

13. Operation in Arctic Areas

Keep the front and rear doors of the equipment closed as much as possible. Keep snow and ice out of the case, and be careful that no moisture accumulates on the short-wave filter.

14. Operation in Desert Areas

Keep both doors closed as much as possible to prevent sand and dust from entering the equipment. Use a soft cloth to wipe the filter, reflector, and lamps before using the equipment. When shaking sand out of the front and rear sections, be careful not to break the spare lamp and filter.

15. Operation in Tropical Areas

Keep both doors closed as much as possible to prevent dirt and moisture from entering the case. Before using the equipment, remove the short-wave filter, and wipe the filter and both ultraviolet lamps with a soft clean cloth. Disconnect the equipment from the power supply when it is not in use. Use carbon tetrachloride to remove any fungus growth or corrosion that may accumulate on the electrical connectors.

Caution: Repeated contact of carbon tetrachloride with the skin or prolonged breathing of the fumes is dangerous. Make sure adequate ventilation is provided.

CHAPTER 3

ORGANIZATIONAL MAINTENANCE INSTRUCTIONS

Section I. PREVENTIVE MAINTENANCE SERVICES

16. Tools, Materials, and Test Equipment Required

The only special tool necessary for organizational maintenance of Electric Light Assembly MX-1291/PAQ is a screw driver, which, is supplied with the equipment. It is held by metal clips in the storage compartment at the rear of the chassis. Multimeter TS-297/U, or equivalent, is required to check the battery. Materials necessary for maintenance are #0000 sandpaper; solvent, dry-cleaning (SD); carbon tetrachloride; and a clean, dry, lint-free cloth.

17. Definition of Preventive Maintenance

Preventive maintenance is work performed on equipment, usually when the equipment is not in use, to keep it in good working condition so that break-downs and needless interruptions in service will be kept to a minimum. Preventive maintenance differs from trouble shooting and repair because its object is to *prevent* trouble from occurring. The importance of preventive maintenance cannot be overemphasized. Failure or inefficient operation of one part of the equipment may cause the failure of other parts. It is vitally important, therefore, that operators and repairmen maintain their equipment properly.

18. General Preventive Maintenance Techniques

- a. Use #0000 sandpaper to remove corrosion.
- b. Use a clean, dry, lint-free cloth for cleaning.
 - (1) If necessary, *except for electrical contacts*, moisten a cloth or brush with solvent (SD) and clean dirty parts; then wipe the parts with a dry cloth.
 - (2) Clean electrical contacts with a cloth moistened with carbon tetrachloride; then wipe them dry with a clean cloth.

c. If it is available, use dry compressed air at a line pressure not exceeding 60 pounds per square inch to remove dust from inaccessible places; be careful, however, or mechanical damage may result from the air blast.

19. Preventive Maintenance Checklist

The following checklist shows preventive maintenance procedures for Electric Light Assembly MX-1291/PAQ. The list contains information on what to check, when to check, how to check, and precautions to be taken before, during, and after checking.

| Item No. | What to check | When to check | How to check | Precautions |
|----------|--------------------|-------------------------|--|--|
| 1 | Short-wave filter. | Before using. | Remove filter and examine it for breakage. Wipe off condensation or finger marks with soft cloth. | |
| 2 | Battery BA-419/U. | Daily, or before using. | Use Multimeter TS-297/U to check for 90-volt output. | See that wires are not disconnected from battery plug. |
| 3 | Black-light lamp. | Weekly. | See whether it is cracked or broken. Turn switch on to see that lamp lights. | See that lamp is seated securely in lampholders. |
| 4 | Germicidal lamp. | Weekly. | See whether it is cracked or broken. Turn switch on to see that lamp lights. | See that lamp is seated securely in lampholders. |
| 5 | Control panel. | Weekly. | Connect battery and check d-c operation. Then plug cable into a-c outlet and check a-c operation. | Be sure that switches operate lamps on both ac and dc. |
| 6 | Power cable. | Weekly. | Check for abrasions, cuts, and breaks in insulation. Repair with friction tape, if necessary. | |
| 7 | Connectors. | Weekly. | Inspect for dirt, mildew, corrosion, and bent or spread contacts. Check for loose mounting screws. Clean and straighten contacts and restore tension. Tighten mounting screws. | |
| 8 | Lampholders. | Weekly. | Examine for loose mounting screws and connections. Clean; tighten screws and connectors. | |

Section II. WEATHERPROOFING

20. Weatherproofing

a. General. Signal Corps equipment, when operated under severe climatic conditions such as prevail in tropical, arctic, and desert regions, requires special treatment and maintenance. Fungus growth, insects, dust, corrosion, salt spray, excessive moisture, and extreme temperatures are harmful to most materials.

b. Tropical Maintenance. A special moistureproofing and fungi-proofing treatment has been devised which, if properly applied, provides a reasonable degree of protection. This treatment is explained fully in TB SIG 13 and TB SIG 72.

c. Winter Maintenance. Special precautions necessary to prevent poor performance or total operational failure of equipment in extremely low temperatures are explained fully in TB SIG 66 and TB SIG 219.

d. Desert Maintenance. Special precautions necessary to prevent equipment failure in areas subject to extremely high temperatures, low humidity, and excessive sand and dust are explained fully in TB SIG 75.

21. Painting and Refinishing

Check all surfaces for appearance and condition of finish. From a protective and durability standpoint, the finish should not show decided wear and should not be chipped or otherwise damaged. Where the finish has been removed completely or worn thin, retouch the affected surfaces, after cleaning and sanding, by applying olive-drab enamel in accordance with existing regulations.

Caution: Do not use steel wool. Minute particles may enter the case and cause harmful shorting or grounding of circuits.

Section III. TROUBLE SHOOTING AT ORGANIZATIONAL MAINTENANCE LEVELS

22. Scope

a. The trouble shooting and repair that can be performed at the organizational maintenance level are limited in scope by the tools and replaceable parts available and by the existing tactical situation.

b. This section will help the repairman to determine the cause of trouble and will suggest what corrective action may be taken. A reference to chapter 4 indicates that the required repairs or adjustments should be made by field maintenance personnel and not by personnel at the organizational maintenance level.

23. Trouble Shooting Using Equipment Performance Checklist

a. *General.* The equipment performance checklist (par. 24) will help the operator to locate the source of trouble. This list gives the item to be checked, the action or condition under which the item is to be checked, normal indications, and corrective measures.

b. *Action or Condition.* The information given in the *action or condition* column consists of various control settings under which the item is to be checked.

c. *Normal Indication.* The normal indications listed are visible signs that the operator should perceive when he checks the item. If indications are not normal, the operator should apply the recommended corrective measures.

d. *Corrective Measures.* The corrective measures listed are those the operator can apply without turning the equipment in for repairs. If the equipment is completely inoperative, or if the recommended corrective measures do not yield results, trouble shooting at the field maintenance level is required (ch. 4).

24. Equipment Performance Checklist

| | Item No. | Item | Action or condition | Normal indication | Corrective measures |
|---|----------|----------------------------|--|--|--|
| A C O P E R A T I O N | 1 | Power cable. | Plug into control panel connector and into 110-volt, 60-cycle, a-c power source. | | |
| | 2 | Power switch. | Throw to AC ON position. | | |
| | 3 | ON MOMENTARY—OFF switches. | Hold each switch at the ON position for a few seconds, and then release it. (After one of the lamps has been lighted, the power switch must be turned to OFF and then back to AC ON before the other lamp is energized.) | The germicidal lamp and the black-light lamp light as the associated switch for each is operated. Germicidal lamp glows with a deep blue-violet hue. Black-light lamp glows with a steady deep violet hue. | Be sure that power switch is in the AC ON position. If either or both of the lamps fail to light, reset them securely in their sockets. Substitute spare lamp for lamp that does not light. If the germicidal lamp lights, but does not glow with the proper hue, replace the short-wave filter (par. 29a(2)). Be sure that power cable is plugged in securely at control panel and power source. Check cable for breaks or shorts, and repair it if necessary. Refer to chapter 4. Refer to chapter 4. |
| | 4 | Power switch. | Throw to OFF position. | Lamps are turned off. | |
| | 5 | Power cable. | Disconnect from control panel and power source. | | |

| | | | | | |
|---|----|--|---|-----------------------|---|
| D C O P E R A T I O N | 6 | Battery BA-419/U. | Connect battery plug to battery (fig. 6). | | |
| | 7 | Power switch. | Throw to DC ON position. | | |
| | 8 | ON MOMEN- TARY— OFF switches. | Same as for item 3. | Same as for item 3. | Same as for item 3, except that power switch must be in DC ON position. |
| | 9 | Power switch. | Throw to OFF position. | Lamps are turned off. | Refer to chapter 4. |
| | 10 | Battery BA-419/U. | Disconnect Battery BA-419/U. | | |

CHAPTER 4

FIELD MAINTENANCE INSTRUCTIONS

Note. This chapter contains information for field maintenance. The repairs that can be performed by units having field maintenance responsibility are limited only by the tools and test equipment available and by the skill of the repairman.

Section I. TROUBLE SHOOTING AT FIELD MAINTENANCE LEVEL

25. Theory of Equipment

(figs. 8 and 9)

Electric Light Assembly MX-1291/PAQ operates on the principle that most solids and liquids and some gases fluoresce, or glow, when excited by ultraviolet light. Each material exhibits characteristic fluorescence by radiating light of a distinctive color and brilliance (par. 11b.) The property of materials has many criminological and military applications (par. 3a and b).

a. The equipment is energized by either Battery BA-419/U or by a 110- to 120-volt, 60-cycle, a-c power source. Each of the ultraviolet lamps used in Electric Light Assembly MX-1291/PAQ requires a ballast voltage to preheat the electrodes and bring the lamp quickly to peak radiation. An a-c and a d-c ballast are used. The a-c ballast provides a starting voltage of 110 to 118 volts, and the d-c ballast provides a starting voltage of 90 to 118 volts. The ballast in use then provides operating voltage for the germicidal lamp or the black-light lamp.

b. The 4-watt, U-shaped, germicidal lamp gives off radiation that peaks at 2,537 angstrom units. The short-wave filter used in front of this lamp absorbs some of the wavelengths below 2,537 angstrom units and obscures most of the visible light. Should the lamp be used without the filter, the visible light emitted would be stronger than the ultraviolet radiation. The lamp has an average life of 1,800 hours.

c. The 6-watt, tubular, black-light lamp is constructed of self-filtering, ultraviolet, transmitting glass and requires no additional filter. This lamp has an average life of 1,200 hours and peaks at 3,650 angstrom units.

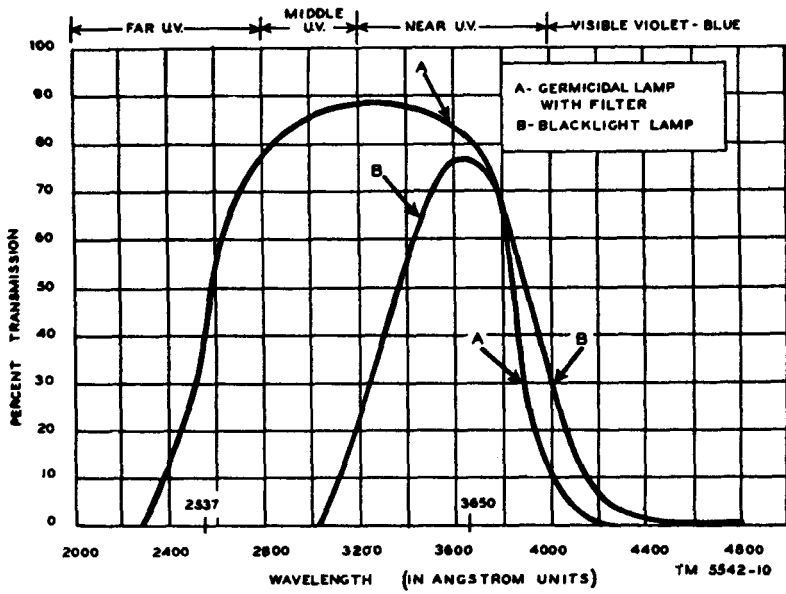

Figure 8. Wavelengths of lamp radiation in angstrom units.

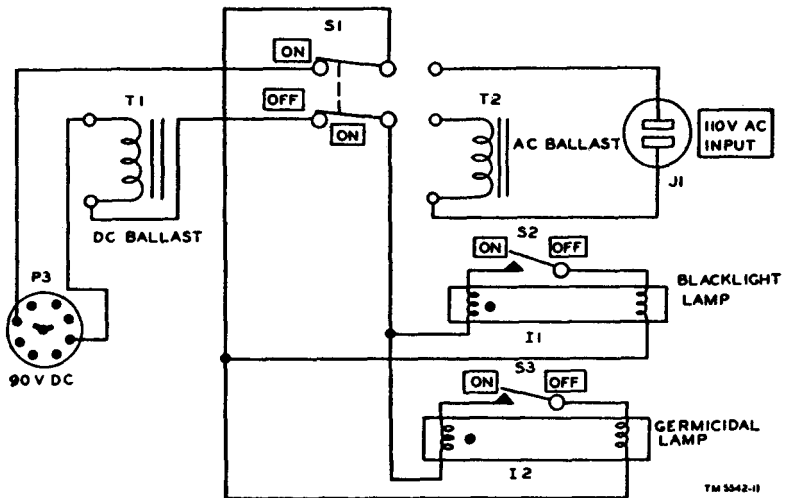

Figure 9. Schematic diagram.

26. Trouble-Shooting Procedures

The first step in servicing a defective equipment is to sectionalize the fault. Sectionalizing means tracing the fault to a major component or circuit. The second step is to localize the fault. Localization means tracing the fault to the defective part. Some faults can be located by smell, sight, or hearing. Other faults must be localized by checking voltage or resistance.

27. Sectionalizing and Localizing Trouble

Before beginning trouble shooting at the field maintenance level, be sure that any applicable corrective measure given in the equipment performance checklist (par. 24) has been tried.

a. Use Multimeter TS-297/U, or equivalent, to check Battery BA-419/U for a minimum voltage of 90 volts. If ac is being used, check the power source for a voltage of 110 to 120 volts.

b. If the power is satisfactory, disconnect the equipment from the power source. Use the multimeter to check continuity of the lamp circuit through plug P3 (fig. 9), ballast T1, and switch S1, to switch S2 and lamp I 1 and to switch S3 and lamp I 2. Then check continuity through from connector J1 and ballast T2 to switch S1. Be sure each switch is closed when it is checked. If a break in the wiring is localized by the continuity tests, resolder the connection or replace the broken wire, as necessary. Replace any switch or ballast shown to be defective by the tests.

c. If the continuity check does not disclose the source of trouble, connect the equipment to an a-c power source and use the multimeter to check voltage at connector J1, the output end of ballast T2, switch S1, and switches S2 and S3. Switch S1 should be in the AC ON position when the checks are made. Replace connector J1, ballast T2, or any of the switches shown to be defective. Disconnect the equipment from the a-c power source, and connect it to Battery BA-419/U. Throw switch S1 to the DC ON position, and check voltage at plug P3 and at the output of ballast T1. Replace any component if it is defective.

d. If the lamps are not extinguished when the power switch is thrown to the OFF position, replace switch S1.

Section II. REPAIRS AND FINAL TESTING

28. Repairs

Repairs of Electric Light Assembly MX-1291/PAQ consist of repairing or replacing damaged wiring, resoldering broken con-

nections, and replacing defective parts. Disassembly and reassembly instructions are given in paragraph 29.

29. Disassembly and Reassembly

(fig. 10)

Disassembly and reassembly of the equipment require only a screwdriver, a pair of pliers, and a soldering iron.

a. Disassembly Instructions.

- (1) *Chassis.* To remove the chassis from the case, first take the battery, cable, screwdriver, and spare parts from the back of the case. Use the screwdriver to remove the two chassis retaining screws (13 and 15) from the control panel and the two (45) from below the short-wave filter mount. Then gently pull the chassis (52) through the rear of the case.
- (2) *Short-wave filter.* To remove the filter frame (30), unscrew the one screw (32) at the top of the frame and the two (34 and 35) at the bottom of the frame. To remove the filter (29), unscrew the one screw that holds it in place at the back of the mount.
- (3) *Reflector.* To remove the reflector (44), first remove the short-wave filter ((2) above), the germicidal lamp (37), and the two black-light lamps (28 and 43). Then remove the four screws (27 and 41) exposed by removal of the black-light lamps, and take out the reflector.
- (4) *Toggle switches.* To remove any of the three toggle switches, use a pair of pliers to unscrew the associated hexagon nut (17, 20, or 21) from the front of the control panel. Then unsolder the wire leads from the switch (4, 7, or 9) at the rear of the control panel, and remove the switch.
- (5) *Input receptacle.* To remove the input receptacle (22), remove the two retaining screws (24) from the front of the control panel. Then unsolder the wire leads, and remove the receptacle.
- (6) *Ballasts.* To remove the d-c ballast (51), unscrew the retaining screw (53), and unsolder the wire leads. To remove the a-c ballast (50), unscrew the two retaining screws, and unsolder the wire leads.

b. Reassembly. To reassemble the equipment, reverse the disassembly instructions (*a* above).

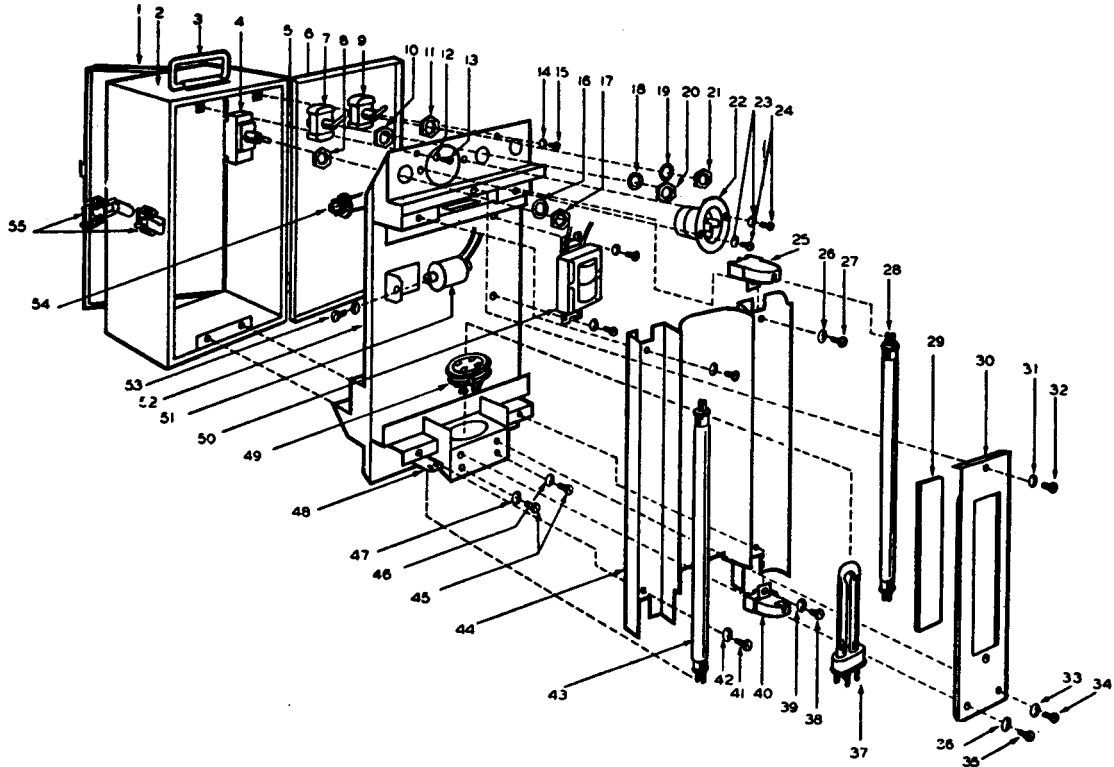

Figure 10. Electric Light Assembly MX-1291/PAQ, exploded view.

TM 5542 - 4

- | | | |
|----------------------|----------------------------|-----------------------------------|
| 1. Rear door. | 20. Nut. | 40. Lampholder. |
| 2. Case. | 21. Nut. | 41. Screw. |
| 3. Handle. | 22. Recessed receptacle. | 42. Washer. |
| 4. Toggle switch S1. | 23. Washer. | 43. Spare black-light lamp. |
| 5. Slip hinge. | 24. Screw. | 44. Reflector O 2. |
| 6. Front door. | 25. Lampholder J2. | 45. Screw. |
| 7. Toggle switch S2. | 26. Washer. | 46. Washer. |
| 8. Backing nut. | 27. Screw. | 47. Washer. |
| 9. Toggle switch S3. | 28. Black-light lamp I 1. | 48. Spare black-light lampholder. |
| 10. Backing nut. | 29. Short-wave filter O 1. | 49. Germicidal lamp socket J203. |
| 11. Backing nut. | 30. Filter frame O 301. | 50. A-c ballast T2. |
| 12. Washer. | 31. Washer. | 51. D-c ballast T1. |
| 13. Screw. | 32. Screw. | 52. Chassis. |
| 14. Washer. | 33. Washer. | 53. Screw and washer. |
| 15. Screw. | 34. Screw. | 54. Battery plug P3. |
| 16. Washer. | 35. Screw. | 55. Latch. |
| 17. Nut. | 36. Washer. | |
| 18. Washer. | 37. Germicidal lamp I 2. | |
| 19. Washer. | 38. Screw. | |
| | 39. Washer. | |

Figure 10-Continued.

30. Final Testing

After the equipment has been repaired, test it as follows before using it:

a. Connect the power cable to a 110- to 120-volt, a-c power source and to the receptacle on the control panel. Throw the power switch to the AC ON position, and check each of the lamps for satisfactory operation by turning on the associated switch for each lamp.

Note. After one lamp has been turned on, the power switch must be thrown to the OFF position and then back to the AC ON position before the other lamp is energized.

b. Disconnect the equipment from the a-c power source, and connect it to the battery. Then check the lamps again as in a above.

CHAPTER 5

SHIPMENT AND LIMITED STORAGE AND DEMOLITION TO PREVENT ENEMY USE

Section I. SHIPMENT AND LIMITED STORAGE

31. Repacking Electric Light Assembly MX-1291/PAQ

a. Place the power cable, the screwdriver, and all spare parts (except the spare black-light lamp) in appropriate compartments in the rear of the case. Place the spare black-light lamp in its compartment in the front of the case.

b. Place a 1-pound bag of silica gel in the battery compartment. Close both doors securely.

c. Place the equipment in a corrugated carton that has a liner and a top and bottom pad.

d. Seal the carton with 3-inch gummed tape, and place the sealed carton in a moisture-vaporproof bag.

e. Place the bag in a suitable, close-fitting, corrugated-cardboard carton and seal all flaps securely with adhesive.

32. Packing for Export Shipping

Place nine packaged cartons (par. 31) in a wooden case 24¾ by 12¾ by 21½ inches in size and lined with case liner. Use metal bands ¾ inch wide by .02 inch thick to strap the case.

Section II. DEMOLITION TO PREVENT ENEMY USE

33. Methods of Destruction

a. Smash. Use sledges, axes, handaxes, pickaxes, hammers, crowbars, or other heavy tools.

b. Cut. Use axes, handaxes, or machetes.

c. Burn. Use gasoline, kerosene, oil, flame throwers, and incendiary grenades.

d. Explode. Use firearms, grenades, TNT.

e. Dispose. Bury in slit trenches, fox holes, other holes. Throw into streams. Scatter.

Note. Use anything immediately available for destruction of this equipment.

34. Destruction of Components

When ordered by your commander, destroy all equipment to prevent its being used or salvaged by the enemy.

a. Smash (par. 33a) filters, lamps, switches, and case.

b. Cut (par. 33b) all wiring.

c. Burn (par. 33c) publications.

d. Bury or scatter (par. 33e) all remaining parts of the equipment.

e. Destroy everything.

APPENDIX I

REFERENCES

Note. For availability of items listed, check SR 310-20-3, SR 310-20-4, SR 310-20-5, and Department of the Army Supply Manual SIG 1 for Signal Corps supply manuals.

1. Army Regulations

- | | |
|----------|--|
| AR 380-5 | Military Security (Safeguarding Security Information). |
| AR 750-5 | Maintenance of Supplies and Equipment (Maintenance Responsibilities and Shop Operation). |

2. Supply Bulletins

- | | |
|--------------|--|
| SB 11-6 | Dry Battery Supply Data. |
| SR 725-405-5 | Issue of Supplies and Equipment, Preparation and Submission of Requisitions for Signal Corps Supplies. |
| SB 11-100 | Serviceability Standards for Signal Equipment in Hands of Troops. |

3. Painting, Preserving, and Lubrication

- | | |
|-----------|--|
| TB SIG 13 | Moistureproofing and Fungiproofing Signal Corps Equipment. |
| TM 9-2851 | Painting Instructions for Field Use. |

4. Camouflage, Decontamination, and Demolition

- | | |
|----------|-------------------------------|
| FM 5-20 | Camouflage, Basic Principles. |
| FM 5-25 | Explosives and Demolitions. |
| TM 3-220 | Decontamination. |

5. Other Publications

| | |
|------------------------------------|---|
| SR 310-20-3 | Index of Training Publications. |
| SR 310-20-4 | Index of Technical Manuals, Technical Regulations, Technical Bulletins, Supply Bulletins, Lubrication Orders, and Modification Work Orders. |
| SR 310-20-7 | Index of Tables. Reduction Tables. |
| SR 310-20-5 | Index of Administrative Publications. |
| SR 700-45-5 | Unsatisfactory Equipment Report (Reports Control Symbol CSGLD-247) |
| SR 745-45-5 | } Report of Damaged or Improper Shipment (Reports Control Symbols CSGLD-66 (Army), SandA-70-6 (Navy), and AF MC-U2 (Air Force)). |
| Navy Shipping Guide Article 1850-4 | |
| AFR 71-4 | |
| TB SIG 25 | Preventive Maintenance of Power Cords. |
| TB SIG 66 | Winter Maintenance of Signal Equipment. |
| TB SIG 72 | Tropical Maintenance of Ground Signal Equipment. |
| TB SIG 75 | Desert Maintenance of Ground Signal Equipment. |
| TB SIG 123 | Preventive Maintenance Practices for Ground Signal Equipment. |
| TB SIG 219 | Operation of Signal Equipment at Low Temperatures. |
| TM 11-430 | Batteries for Signal Communication. Except Those Pertaining to Aircraft. |
| TM 11-661 | Electrical Fundamentals (Direct Current). |
| TM 11-676 | Grounding Procedure and Protective Devices. |
| TM 11-681 | Electrical Fundamentals (Alternating Current). |
| TM 11-5500 | Multimeter TS-297/U. |

APPENDIX II

IDENTIFICATION TABLE OF PARTS

Note. The following is an identification table of parts for Electric Light Assembly MX-1291/PAQ (Sig C stock No. 6Z6933B-1291). The fact that a part is listed in this table is not sufficient basis for requisitioning the item. Requisitions must cite an authorized basis, such as a specific T/O&E, T/A, SIG 7-8-10, SIG 10, list of allowances of expendable material, or another authorized supply basis. The Department of the Army supply manual applicable to the equipment covered in this manual is SIG 7&8-MX-1291/PAQ. For an index of available supply manuals in the Signal portion of the Department of the Army supply manual, see the latest issue of SIG 1.

| Ref symbol | Name of part and description | Function of part | Signal Corps stock No. |
|------------|--|--|------------------------|
| T2 | BALLAST, lamp: 118 v. .158 amp, 60 cyc; 4 1/4" lg x 1 1/4" wd x 1 1/4" h. | Ballast for operating ultraviolet lamps on a-c current. | 6Z808-6 |
| T1 | BALLAST, lamp: 90-115 v, .160 amp, 1 1/2" lg x 1" dia. | Ballast for d-c operation of ultraviolet lamps. | L2C165-2 |
| W201 | CABLE, power: electrical; 2 stranded #18 AWG cond; 300 v. | Used as a-c power cable. | 1B3018-2.28 |
| P1 | CONNECTOR, plug: 2 curved blade female cont slots; straight type; 1.187" lg x 1" dia excl cable clamp. | Female connector on power cable. | 6Z3151 |
| P2 | CONNECTOR, plug: 2 male flat prong cond; straight type; 1 1/2" lg x 1 1/2" dia. | Male connector on power cable assembly. | 6Z1727 |
| P3 | CONNECTOR, plug: 8 rd male; straight; 3/8" lg x 1 1/2" OD x 1 1/4" ID. | Battery connector plug. | 2Z3028-56 |
| J1 | CONNECTOR, receptacle: 2 curved male flat; straight type; 1 3/8" lg, 1 1/8" h. | Control-panel receptacle for accommodating 110-v power cable plug. | 6Z815 |
| O 1 | FILTER, light: opaque; glass; slide-in mtg; 1 1/2" x 6". | Filter for short-wave radiation. | 6Z3853-5 |
| I 1 | LAMP, fluorescent: 6 w. | Long-wave ultraviolet source. | 6Z6876-6.2 |
| I 2 | LAMP, mercury vapor: 4 w. | Short-wave ultraviolet source. | 6Z6901-4 |
| J2 | LAMPHOLDER: 250 v; 75 w. | Holders for lamp I 1. | 6Z8327-8 |
| O 301 | MOUNT, filter: steel; OD finish. | Holds short-wave filter. | 6Z7180 |
| O 2 | REFLECTOR, light: polished aluminum. | Reflects ultraviolet radiation. | 6Z7827.12 |
| J203 | SOCKET, tube: 4 cont, 2 jumbo, 2 med; retaining ring mtg. | Receptacle for 4-w lamp. | 2Z8674.172 |
| S1 | SWITCH, toggle: DPDT; .75/.50 amp; 125/250 v dc. | Power switch for lamps. | 3Z9863-52P |
| S2, S3 | SWITCH, toggle: SPST; JAN type ST42C. | Starter switch for lamp. | 3Z9863.42C |

INDEX

| | <i>Paragraph</i> | <i>Page</i> |
|---------------------------------------|------------------|-------------|
| Application: | | |
| Criminological ----- | 2a | 1 |
| Military ----- | 3b | 2 |
| Arctic areas: | | |
| Operation ----- | 13 | 11 |
| Weatherproofing ----- | 20c | 16 |
| Ballasts: | | |
| Disassembly and reassembly ----- | 29a | 23 |
| Theory ----- | 25a | 20 |
| Black-light lamp: | | |
| Description ----- | 3 | 1 |
| Theory ----- | 25c | 20 |
| Use ----- | 11a | 10 |
| Cable, power, use ----- | 10b | 8 |
| Case, description ----- | 6 | 4 |
| Cleaning ----- | 18b | 13 |
| Components: | | |
| Description ----- | 6 | 4 |
| Table ----- | 5 | 4 |
| Control panel ----- | 9 | 6 |
| Controls and their use ----- | 9a | 6 |
| Demolition of equipment ----- | 33 | 26 |
| Description: | | |
| Case ----- | 6 | 4 |
| Control panel ----- | 6a | 4 |
| Lamps: | | |
| Black-light ----- | 6b | 4 |
| Germicidal ----- | 6b | 4 |
| Rear compartments ----- | 6c | 4 |
| Desert areas: | | |
| Operation ----- | 14 | 12 |
| Weatherproofing ----- | 20b | 16 |
| Disassembly and reassembly: | | |
| Ballasts ----- | 29a | 23 |
| Chassis ----- | 29a | 23 |
| Input receptacle ----- | 29a | 23 |
| Reflector ----- | 29a | 23 |
| Short-wave filter ----- | 29a | 23 |
| Toggle switches ----- | 29a | 23 |
| Equipment operation ----- | 11 | 10 |
| Equipment performance checklist ----- | 24 | 18 |

| | <i>Paragraph Page</i> | |
|--|-----------------------|----|
| Forms: | | |
| AF54----- | 2 c | 1 |
| DA 468----- | 2b | 1 |
| DD 6----- | 2a | 1 |
| General description ----- | 3 | 1 |
| Germicidal lamp: | | |
| Description ----- | 3 | 1 |
| Theory ----- | 25b | 20 |
| Use----- | 11a | 10 |
| Handle, carrying ----- | 6 | 4 |
| Identification of materials ----- | 11 b | 10 |
| Inspection ----- | 8b | 6 |
| Lamps: | | |
| Black-light. (See Black-light lamp.) | | |
| Germicidal. (See Germicidal lamp.) | | |
| Maintenance: | | |
| Field: | | |
| Disassembly and reassembly ----- | 29 | 23 |
| Final testing ----- | 30 | 25 |
| Repairs ----- | 28 | 22 |
| Sectionalizing and localizing trouble ----- | 27 | 22 |
| Trouble-shooting procedures ----- | 26 | 22 |
| Preventive ----- | 19 | 14 |
| Checklist, equipment performance ----- | 19 | 14 |
| Definition ----- | 17 | 13 |
| General techniques ----- | 18 | 13 |
| Painting and refinishing ----- | 21 | 16 |
| Tools and materials required ----- | 16 | 13 |
| Trouble shooting using equipment performance check- list. ----- | 23 | 17 |
| Weatherproofing ----- | 20 | 16 |
| Methods of destruction ----- | 34 | 27 |
| Night uses of equipment ----- | 3b | 2 |
| Operation: | | |
| Under unusual conditions: | | |
| Arctic ----- | 13 | 11 |
| Daylight ----- | 12 | 11 |
| Desert ----- | 14 | 12 |
| Tropical ----- | 15 | 12 |
| Under usual conditions: | | |
| Starting procedure----- | 10 | 8 |
| Using equipment----- | 11 | 10 |
| Packaging data ----- | 7 | 5 |
| Power supply ----- | 4 | 2 |
| Preventive maintenance. (See Maintenance preventive.) | | |
| Procedures, trouble-shooting ----- | 26 | 22 |

| | <i>Paragraph</i> | <i>Page</i> |
|--|------------------|-------------|
| Refinishing | 21 | 16 |
| Repacking | 31 | 26 |
| Repairs | 28 | 22 |
| Scope of manual | 1 | 1 |
| Shipment and limited storage, packing for..... | 32 | 26 |
| Technical characteristics | 4 | 2 |
| Testing, final | 30 | 25 |
| Theory of equipment | 25 | 20 |
| Tropical areas: | | |
| Operation | 15 | 12 |
| Weatherproofing | 20b | 16 |
| Trouble shooting: | | |
| Procedures | 26 | 22 |
| Using equipment performance checklist | 23 | 17 |
| Uncrating, unpacking, and cheating | 8 | 6 |
| Weatherproofing | 20 | 16 |

